

OBD-II: Power train and Emission Control in Passenger Vehicles

DR. PORAG KALITA, Ph.D. (Auto. Engg.)

HEAD - Automobile Engineering Department,
Vocational Education (+2),
M R S Higher Secondary School, Govt. of Assam.
Titabor, Jorhat, ASSAM, INDIA.
Email:poragkalita@rediffmail.com

Abstract:- OBD-II provides additional information to engineer for diagnosis and repair of emissions related problems. OBD-II, standardizes on the amount of memory (Freeze Frame) it uses to store the readings of the vehicle sensor when it logs on emission related Intermittent Trouble code (IT). The intent of OBD-II, systems is to detect most vehicle malfunctions when performance of a power train component or system deteriorates to the point that the vehicle's HC emission exceed standard. The vehicle operator is notified at the time when the vehicle begins to marginally exceed emission standards, by illuminating the Malfunctions Indicator Light (MIL).

Index Terms- Crank angle Idle Air Control Valve, Malfunctions Indicator Light (MIL), Mass Air Flow (MAF) sensor. Power train, Tractive Resistance, UBHC Emission, etc.



1. INTRODUCTION

First major clean air act was adopted by the congress in 1970. Congress established the Environmental Protection Agency (EPA), with the overall responsibility of regulating motor vehicle pollution to the atmosphere. Congress also identified the inspection and Maintenance for improving the air quality.

The power train components towards emission controls are:

- 2.1. Throttle and Manifold,
- 2.2. Exhaust and Fuel system,
- 2.3. Combustion and Rotational dynamic,
- 2.4. Automatic Transmission, etc.

For example, Throttle and Manifold, this is consisting by the following sub-components:

- # Throttle body assembly,
- # Idle Air Control Assembly,
- # Exhaust Gas Re-circulation,

Power train subsystem consist of the engine and transmission including the exhaust emission control apparatus which needs to be continuously monitored by the engine controller (Computer) for potential defects leading to decreased effectiveness in emission control system, e.g. three way catalyst.

2. LITERACY REVIEW:

On-line diagnosis of internal combustion engines in passenger vehicles is mandated due to the strict environmental regulations in the U.S.A. and in some European Countries (e.g. , the EFTA (European Free Trade Agency) Partners') to control Hydro carbon emissions from the exhaust.

UBHC emission can reduce the vehicle speed. By the method of positive crankcase ventilation (PCV) method, it is increased oil consumption and low speed air-fuel mixture burnt properly. However, study shown that PCV does not control UBHC emission properly. (As per thermodynamic gas law, engine

operation is depending Air-fuel i.e. method of ignition of the Internal Combustion Engine. As per method of internal combustion Hydrogen mixed O₂, produce H₂O (Water), Carbon mixed with O₂, produced CO, CO₂ etc. Because, Hydrocarbon is consisting by Hydrogen and Carbon.) Fuel Injector method which is depending towards control UBHC emission and this system is consisting the following.

2.1. Standard Port Fuel Injection System (SPFI);

This system is produce more UBHC emission at cold start and it is operated by Stoichiometric conditions. (*Stoichiometric: At high load, where stoichiometric operation is maintained by EGR).

2.2. Air Force port fuel injection (AFPFI) or Air Assisted port Fuel Injection (AAPFI) system:

This system used as Air Injection system and as per experimental study it was found that this system does not reduce UBHC emission.

2.3. Gasoline Direct Injection:

It is consists of four valve, pent-roof cylinder head, silica made cylinder (Optical fiber) and running without water cooling system, and this heat control by intake air heater for room temperature(Temperature 105 degree centigrade) and in this way may control the UBHC emission from the automobiles.

In terms of adiabatic process—

(1)During the compression, as per thermodynamics gas law in side cylinder pressure and temperature raise but volume decreases for the applications of Boyle’s law, V∞I/P and application of Charles’s law pressure remaining constant, volume fixed, P ∞ T.

3. METHODOLOGY:

The power train functions are described to show how the PCM controls the emissions while delivering the torque to the vehicle requested to the driver.

3.1. Throttle and Intake Manifold:

The throttle body assembly in an air valve, it regulates the air flow into the engine and thereby contribute to the control of engine speed and power. IACV (Idle Air Control Valve) provides additional air flow during starting of the engine and during idle. IACV

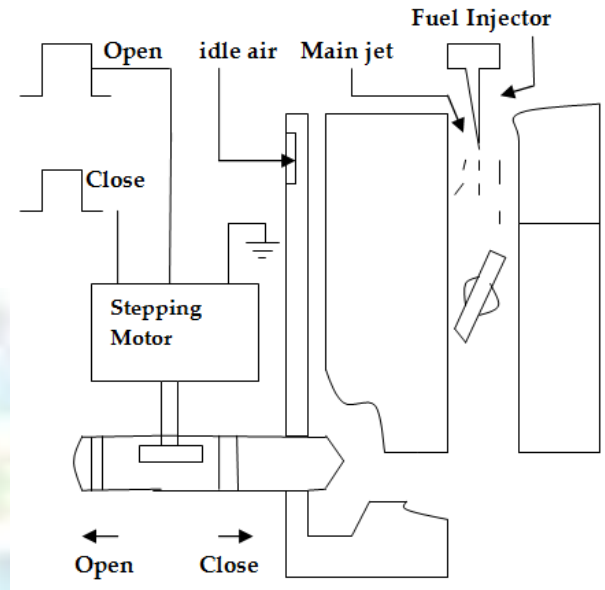

Fig: 3 (a) Idle Air Control.

By pass the throttle to provide additional air to compensate for the load during closed throttle. EGR provides exhaust gases to the intake manifold. This has the effect of reducing oxygen content in the engine.

For example, a petrol engine consumes 6.35 kg of petrol per hour. The specific gravity of petrol is 0.7. The fuel air ratio is 0.066. The diameter of the single jet of the carburetor 1.27 mm and its top is 3 mm above the petrol level. Average condition of air is 15.5 C and 1,027 kg/cm². The values discharge coefficient for fuel and air respecting are 0.6 and 0.8. Find the critical air velocity and effective throat diameter of the venturi. What is the drop of pressure in the venturi, expressed in cm of water.

Solution:

Density of air at given conditions:

$$\rho = \frac{1.027 \times (10)^4}{29.27 \times 2888.5} = 1.215 \text{ kg/m}^3$$

Neglecting the compressibility effect on air, critical air velocity:

$$V_a (\text{critical}) = K_a \sqrt{2g \times \frac{p_f}{\rho_a}}$$

$$= 0.8 \sqrt{\frac{2 \times 9.81 \times 3 \times 700}{1000 \times 1.215}} = 4.65 \text{ m/sec}$$

Petrol flow per second,

$$W_f = A_f \cdot K_f \cdot \sqrt{2g \cdot p_f (\Delta P_a - x \cdot P_f)}$$

$$\text{Or, } = \frac{6.35}{60 \times 60} = \frac{\pi (1.27)^2 \times 0.6}{(10)^4} \sqrt{(2 \times 9.81 \times 700)} \sqrt{(\Delta P_a - \frac{3}{1000} \times 700)}$$

$$\text{Or, } \sqrt{1.4000 \times 9.81 (\Delta P_a - 2.1)} = 2.310$$

$$\therefore \Delta P_a = 390.1 \text{ kg/cm}^2$$

Using the relation, $p = wh$, $h = \frac{p}{w}$

$$\Delta P_a = \left(\frac{390.1}{1000}\right) \text{ meters of water.}$$

$$= .39 \text{ meters of water,}$$

$$= 39 \text{ cm of water.}$$

Air flow per second:

$$W_a = K_a \cdot A_a \sqrt{2g \cdot P_a \cdot \Delta P_a}$$

$$\frac{6.35}{0.066 \times 3.600} = 0.8 \times A_a \sqrt{2 \times 9.81 \times 1.215 \times 390.1}$$

$$\therefore 0.8 \times A_a \sqrt{9.320}$$

$$= 2.7 \times (10)^{-2}$$

$$\therefore \frac{\pi}{4} d_a^2 = \frac{2.67 \times (10)^2}{0.8 \times \sqrt{9.320}}$$

$$\therefore d_a = 4.41 \times (10)^{-4}$$

$$d_a = 2.1 \times 10^2 \text{ meters.}$$

$$\therefore \text{Throat diameter venturi} = 2.1 \text{ cm.}$$

3.2. Cylinder:

This in turn reduces the combustion temperature of the cylinder flame. This has the important effect of reducing the NOx (Oxides of Nitrogen) emissions. Intake manifold is the main air passage from the throttle valve to the engine cylinders. The amount of air through the intake manifold to the cylinder is the same for each cylinder on each intake stroke. Then each cylinder requires an amount of fuel determined by the density of the air in the cylinder. MAP sensor is used to compute the density of the air in the manifold. Barometric absolute pressure is used to compute the EGR flow. The Manifold vacuum is the difference

between these two pressures which measured. The required fuel is in direct proportion to this air mass which is controlled by the PCM to maintain the exact stoichiometric ratio (14.7) of air/fuel that gives the minimum HC emissions.

3.3. Exhaust & Fuel System:

Exhaust valves of the engine cylinders purge the exhaust through the Exhaust Gas line which then passes through the catalytic converters in which most of the HC and CO are oxidized to CO₂ and Water. The extra oxygen required for this oxidation is supplied by adding air to exhaust stream from an engine driven air pump. This air called secondary air is normally introduced into the exhaust manifold. This has a considerable effect in reducing emissions.

The Fuel Pump supplies metered fuel which is electronically injected through nozzles operated by solenoids under control of the PCM. The fuel in the fuel tank is filtered. The Fuel Level Sensor measures the inlet vacuum which is a measure of fuel pump suction which affects pump priming.

4. RESULT & DISCUSSION:

4.1. Automatic Transmission:

The Automatic Transmission uses a hydraulic or fluids coupling to transmit engine power to the wheels, (Fluid Coupling: A device in the power train consisting of two rotating members. It transmits power through a fluid from the engine to the remainder of the power train). Efficient transmission of engine output to the automatic transmission input shaft is performed through a transmission lockup clutch similar to a standard pressure plate clutch placed inside the torque converter.

In order to smoothly engage the lockup clutch the hydraulic pressure is adjusted by controlling the output current applied to the lockup solenoid valve. (Solenoid is a type of electro-magneto, often used to operate the starter motor switch).

Automatic transmission is controlled by inputs from the vehicle speed sensor and throttle position sensor which senses the vehicle load. The automatic gear shift points, the point at which the lockup clutch is activated, and the clutch's hydraulic pressure level are controlled by the Power Control Module (PCM). The optimal shifts and lockup operations are carried out

using a solenoid valve to open and close the hydraulic circuit, primed by the hydraulic pump.

The transmission's input-shaft speed is monitored during shifting by the speed sensor after the ON/OFF signal is output from the shift solenoid valves. The shifting process is adjusted by the hydraulic pressure of the clutch so that the clutch is smoothly engaged. The engine torque is controlled in synchronism with the shift to reduce impact due to shift. During cruise, the lockup clutch is engaged and is disengaged during shifts, which improves fuel economy and emissions.

4.2. Resistance to the Motion of the vehicle:

A thrust known as tractive effort or force is provided by the power unit of a vehicle at the driving road wheels. Varying at different engine speeds and gear positions, it is mainly required to overcome the force of opposing motion of the vehicle. The resistance to the motion of the vehicle is known as tractive resistance. These resistances are:

1. Rolling and frictional resistance (R_r) in kg.
2. Gradient resistance (R_g) in kg.
3. Air or wind resistance (R_a) in kg.

$$R = R_r + R_g + R_a$$

4.2.1. Rolling Resistance:

It is the force necessary to maintain constant speed on a level road and the rolling resistance generally varies with the type of the road surface, load on each tyre, inflation pressure and type of tyre trend.

The value rolling resistance can be calculated from the formula:

$$R_r = k_r \cdot W$$

Where, W = Total weight of the vehicle in kg.

k_r = constant of rolling resistance.

4.2.2. Gradient resistance:

It is the force opposing forward motion of a vehicle up a gradient. This resistance does not depend upon the speed of the vehicle. It is expressed as,

$$R_g = W \sin \theta,$$

Where, W = Total weight of the vehicle kg.

θ = inclination of the slope to the horizontal,

When expressed as a percentage, it is percent gradient,

$$= 100 \times \tan \theta = 100 \sin \theta$$

4.2.3. Wind or Air resistance:

Wind or air resistance is dependent upon speed, the shape of the vehicle body and wind velocity and it is given by:

$$R_a = K_a \cdot A \cdot V^2$$

Where, A = projected frontal area in m^2

V = speed of the vehicle in km/hr.

K_a = Co-efficient of air resistance.

= 0.00235 for best stream lined cars,

= 0.0032 for average cars,

= 0.0046 for trucks and Lorries.

4.3. Different Drive of Vehicle:

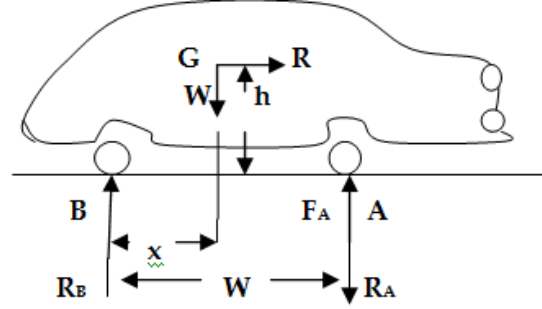

Fig: 4(a) Drive of Vehicle

A vehicle with wheel base w and height C . G from the road surface h is moving on a straight road by acceleration f . Let W is the weight of car and μ is co-efficient of adhesion, between the tyres and the road surfaces. R_A and R_B are the normal reactions at front and rear wheels respectively as shown in figure 4(a).

4.3.1. Front Wheel Drive:

The body is in equilibrium under the various forces shown in figure 5(a).

Maximum tractive effort, $F_A = \mu \cdot R_A$ gives maximum forward acceleration f and $\frac{W}{g} - f$ is the inertia force opposite to acceleration f .

Sum of all the horizontal and vertical should be equal to zero individually.

$$\begin{aligned} \therefore R_A + R_B &= W \\ F_A &= \mu R_A = \frac{W}{g} f \end{aligned}$$

4.3.2. Rear Wheel Drive:

In this case, the tractive effort acts only on rear wheels instead of acting at front wheels as in the previous case. Maximum tractive effort:

$$F_B = \mu R_B$$

Equating sum of vertical and horizontal forces to zero individually,

$$R_A + R_B = W$$

$$FB = \frac{\mu \times RB}{W} = g \cdot f$$

6. TYPE OF DATA:

5.1. Idle and Low Speed System:

The supply of fuel between engine rotation rates of 350 – 600 rpm is controlled by this system. Idle rpm is the speed below which the engine would refuse to run. This is dependent on the design parameter of the venture tube and intake manifold. During idle operation of the engine, the air flow is greatly reduced resulting in decreased primary evaporation and atomization of the petrol droplets. The pressure difference between the fuel level and venture throat becomes insufficient to allow flow of fuel through the main jet.

The idling system has a passage connected to

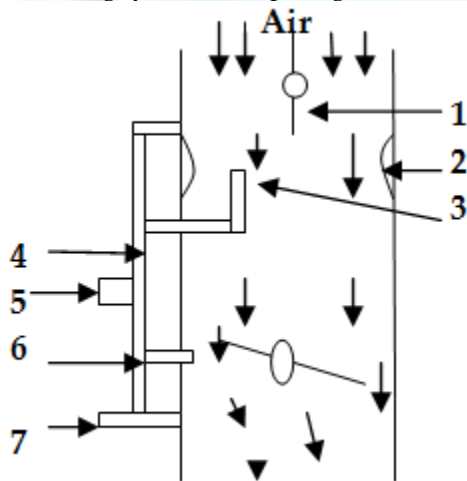

Fig :5 (a) Idling Circuit .

1. Choke valve.
2. Venturi,
3. Main Nozzle.
4. Auxiliary air passage,
5. petrol from float chamber,
6. idle hole,
7. Idle mixture adjustable screw,

the float chamber and the main jet . A smaller jet known as slow running or idle jet is arranged in the same passage. This passage, in turn is connected with another passage, the end of which is open to atmosphere. A spring load conical ended screw is provided at this end through which can pass

atmosphere air in fixed quantities. The opening of this passage is situated below the throttle valve. The throttle valve opening is controlled by another spring loaded screw.

Petrol comes from the float chamber via the main jet and enters the other passage though the idling jet. Here it meets the atmospheric air adjustable by a screw. The mixture formed due to emulsification of air passing through the venture tube. Here the fuel droplets are atomized. The engine rpm depends upon the degree of throttle valve opening.

6. CONCLUSION:

6.1. Combustion and Rotational dynamics:

The engine provides the mechanical power to the vehicle. The engine cylinders perform the combustion of air/fuel mixture at stoichiometric ratio (14.7). The Crankshaft assembly and flywheel house the crank angle which senses the position of the Top Dead Centre (TDC) of the cylinder and provides the necessary ignition spark at the correct crank angle between the reference point on the flywheel and the horizontal centerline of crank shaft. The amount of fuel needed for the combustion in the engine cylinder is a direct function of the throttle position and the mass of air through the intake manifold which is controlled by the drivers accelerator pedal. This mass of air is measured with the Mass Air Flow (MAF) sensor. The correct air mass is computed by compensating for the intake air temperature which is measured by the intake air temperature sensor. The Manifold Absolute Pressure (MAP) sensor measures the intake manifold pressure which is also used to measure the amount of air going into the cylinder as a second method to determine the amount of fuel that should be sent to the fuel injection nozzles for spraying into the cylinder. This is to ensure that accurate amount of fuel is used in the cylinder to achieve fuel economy as well as to reduce emission by effective combustion. An engine speed sensor is needed to provide an input PCM to compute ignition timing. Engine speed is measured by engine speed sensor similar to crankshaft position sensor. Another variable which must be measured for engine control is the throttle valve position which is measured by the Throttle Angle Sensor.

The throttle plate is mechanically linked to the accelerator pedal which is operated by the driver. When the pedal is pressed the throttle plate rotates and

allows more air to pass through the intake manifold. The angle of rotation of throttle plate is measured by the throttle angle sensor. This can be used to measure the mass of air going into cylinder.

For Example, in terms of Critical Air Velocity, the minimum velocity of air the venture at which the fuel just begins to flow is termed as the critical air velocity.

The pressure difference which causes the fuel flow is $(\Delta P_a - X.P_f)$.

If $\Delta P_a = X.P_f$, the fuel will be raised to the top of the jet orifice, but there will be no flow of fuel.

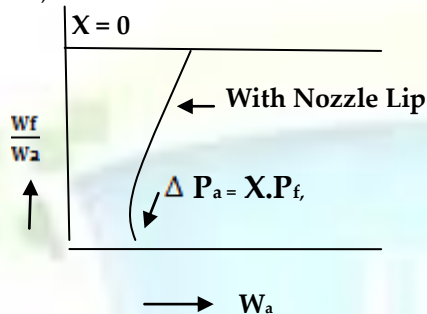

Fig: 6(a) Air Velocity (Critical)

Fuel flow will start when $\Delta P_a > X.P_f$,

$$\text{Now, } \therefore u_2 = K_a \sqrt{\frac{2g \cdot \Delta P_a}{P_a}}$$

$$\text{and, } U_f = K_f \sqrt{\frac{2g \cdot (\Delta P_a - x \cdot P_f)}{P_f}}$$

$$\therefore \frac{V_a^2 \cdot P_a}{K_a^2} = \frac{V_f^2 \cdot P_f}{K_f^2} + 2g \cdot x \cdot P_f$$

$$\text{If, } V_f = 0, V_a = K_a \sqrt{\frac{2g \cdot x \cdot P_f}{P_a}}$$

This is the critical air velocity at which the fuel just begin to flow.

However, knock is caused by a rapid rise in cylinder pressure during combustion caused by high manifold pressure (MAP) and excessive spark advance. It is important to detect knock and avoid excessive knock to avoid damage to the engine. Knock is detected by the Knock sensor.

During engine off condition, the fuel stored in the fuel system tends to evaporate into the atmosphere. To reduce these HC emissions, they are collected by a charcoal filter in a canister. The collected fuel is

released into fuel intake through a purge solenoid valve controlled by the PCM periodically.

7. REFERENCES:

- [1] Proceeding of SAE International Total Life Cycle Conference & Exposition in Michigan, USA, 2000.
- [2] SAE paper no. 2000-01-1477 by Dr.Porag Kalita, M R S Higher Secondary School, Titabor, Assam, India.
- [3] Seminar On Board Diagnostics – II, by Prof. S. Ganeshan, Oakland University, USA/2000.